

# CAB SIZES FOR 500 LB WINDING DRUM

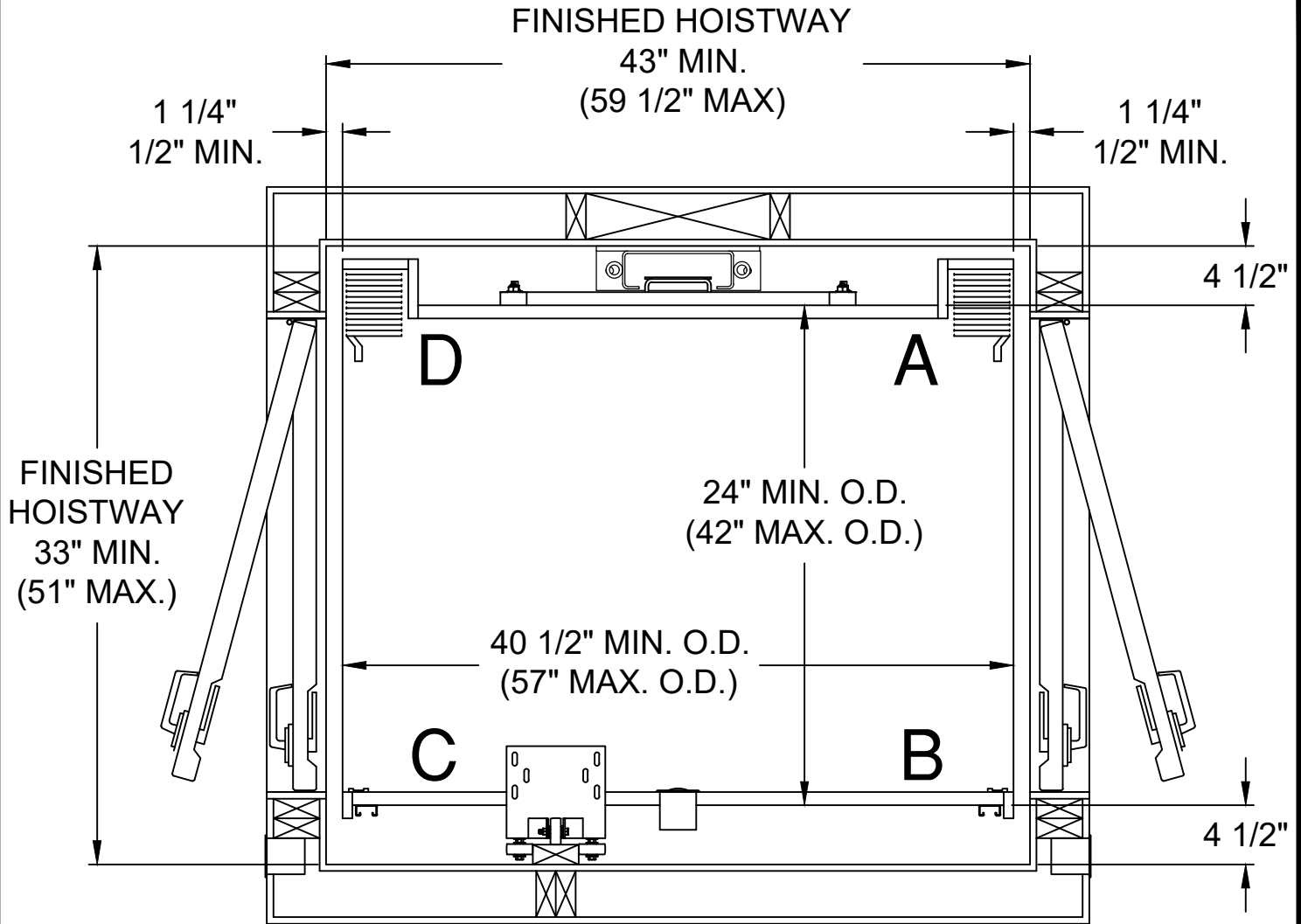

**SINGLE OPENING - 36 1/4" O.D. MINIMUM**  
 (RAIL IS NOT CENTERED IN THE HOISTWAY)

**NOTE:**

1. MIN. DA DIMS. REFLECT RAIL CENTERED IN HOISTWAY.
2. MIN. DA DIM. FOR CAB WITHOUT RECESS IS 24" O.D.
3. MIN. DA DIM. FOR CAB WITHOUT GATE RECESS IS 24" O.D.  
 CAB I.D. CANNOT EXCEED 12 SQ. FT.

<b>FOX VALLEY</b>		1726 North Ballard Road Appleton, WI 54911 Phone: 800-238-8739	
<b>ELEVATOR™</b>			
ELEVATOR CONTRACTOR:			
JOB NAME:		ORDER NUMBER:	
<b>WINDING DRUM 500LB. MIN. &amp; MAX. CAB DIMENSIONS</b>			
DRAWN BY: PJS	DATE: 10/16/23	SIGNATURE OF APPROVAL	DWG. NO. C-002042