

36' <= 50' Cover is 3" wider

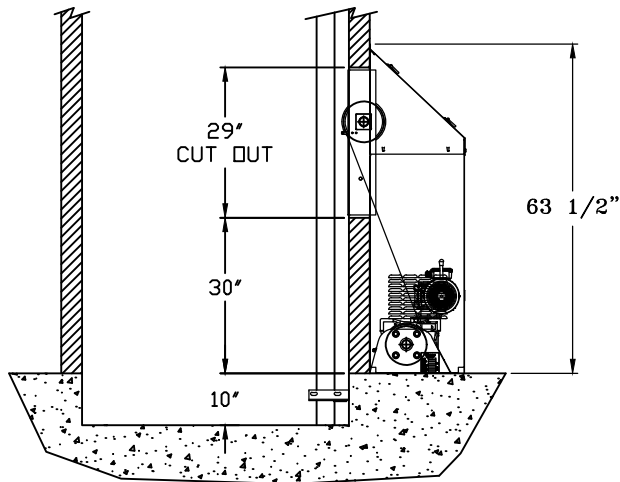

TRAVEL (FEET)	<22	<36	<50
DRUM LENGTH (INCH)	12	18	24
STARTING WRAPS ON DRUM	2	2	2

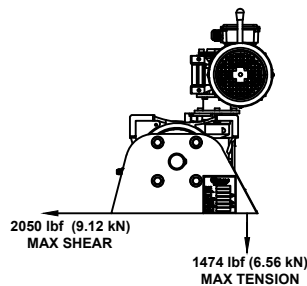

FOX VALLEY
ELEVATOR™

1726 North Ballard Road
 Appleton, WI 54911
 Phone: 800-238-8739

ELEVATOR CONTRACTOR:			
JOB NAME:		ORDER NUMBER:	
EXCELEVATOR RMR WINDING DRUM ELEVATOR TRAVELING SHEAVE MACHINE ROOM			
DRAWN BY:	DATE:	SIGNATURE OF APPROVAL	DWG. NO. C-002830