

NOTE:

- 1) DISTANCE BETWEEN THE FACE OF THE HOISTWAY DOOR AND EDGE OF LANDING SILL SHALL NOT EXCEED 3/4".
- 2) MUST REJECT 4" DIAMETER BALL AT ALL POINTS WHEN HOISTWAY DOOR AND CAR DOOR ARE IN FULLY CLOSED POSITION.
- 3) HOISTWAY BY OTHERS PER CODE. WALLS TO BE PLUMB AND SQUARE. ALL HOISTWAY DOORS BY OTHERS PER CODE.
- 4) PRUDHOMME LRCE DOOR INTERLOCKS. (**SPECIAL DOOR FRAMING REQUIRED ON LATCH SIDE**)
- 5) FINISHED HOISTWAY = ROUGH FRAMING + DRYWALL + PLASTER + PAINT.

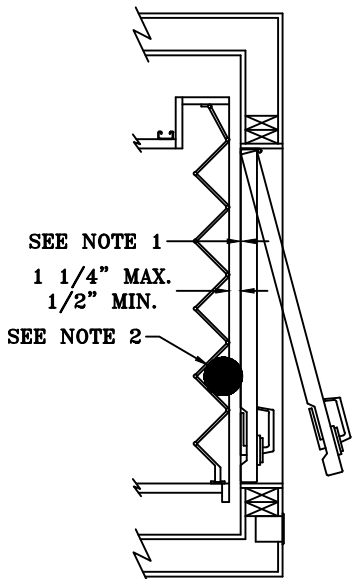
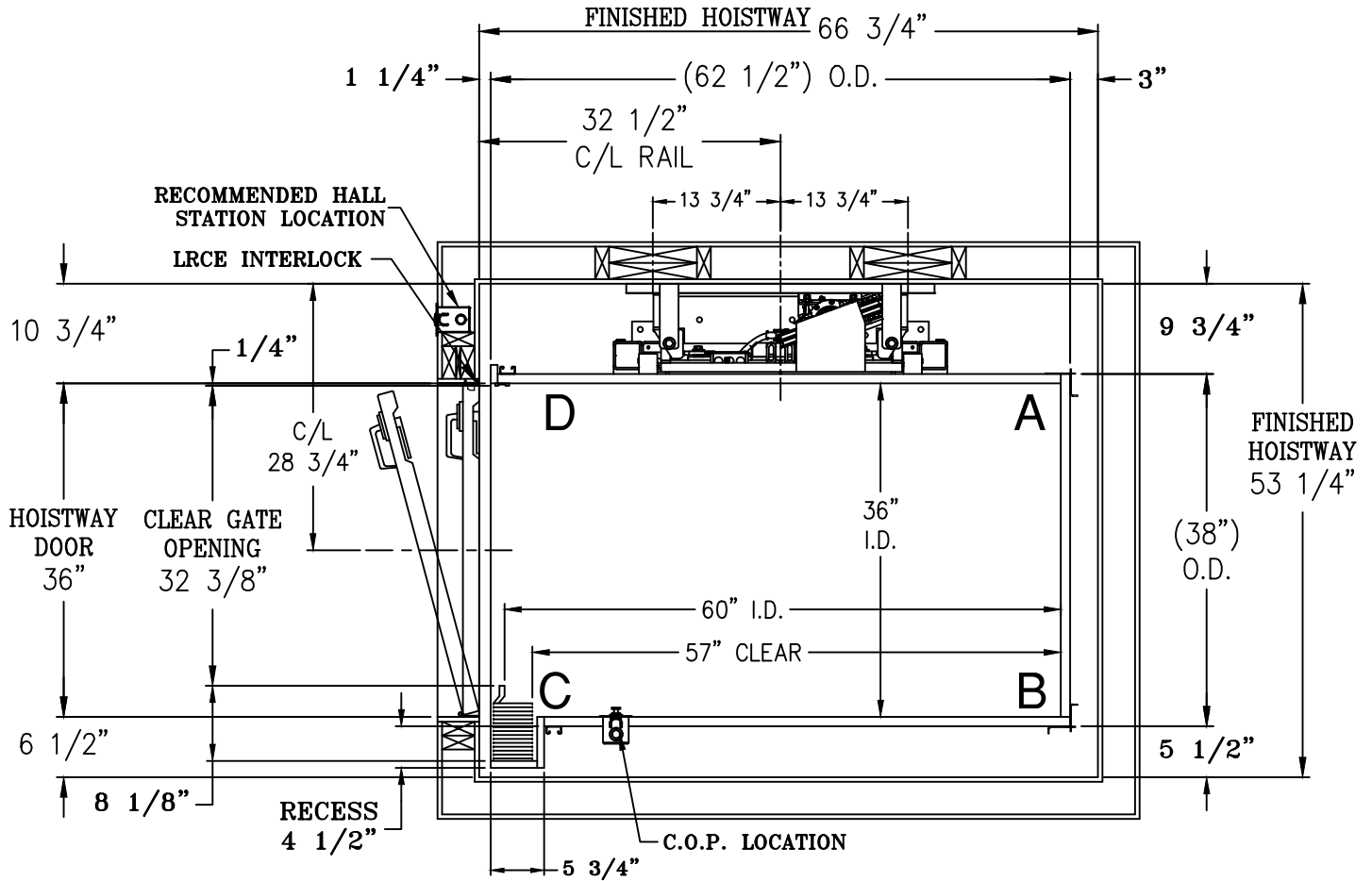

| | | | |
|---|-------|--|-----------------------------|
| FOX VALLEY | | 1726 North Ballard Road Appleton, WI 54911 Phone: 800-238-8739 | |
| ELEVATOR™ | | | |
| ELEVATOR CONTRACTOR: | | | |
| JOB NAME: | | ORDER NUMBER: | |
| PACA SERIES HYDRAULIC ELEVATOR CDR OPENING W/ ACCORDION GATE | | | |
| DRAWN BY: | DATE: | SIGNATURE OF APPROVAL | DWG. NO. C-002662 |