

DOOR SPACE GUARD REQUIRED TO COMPLY WITH ASME A17.1-2019 SECTIONS 5.3.1.8.2 AND 5.3.1.9.3 (b). CONTACT LOCAL CODE AUTHORITY FOR SPACE GUARD SIZE REQUIREMENTS.

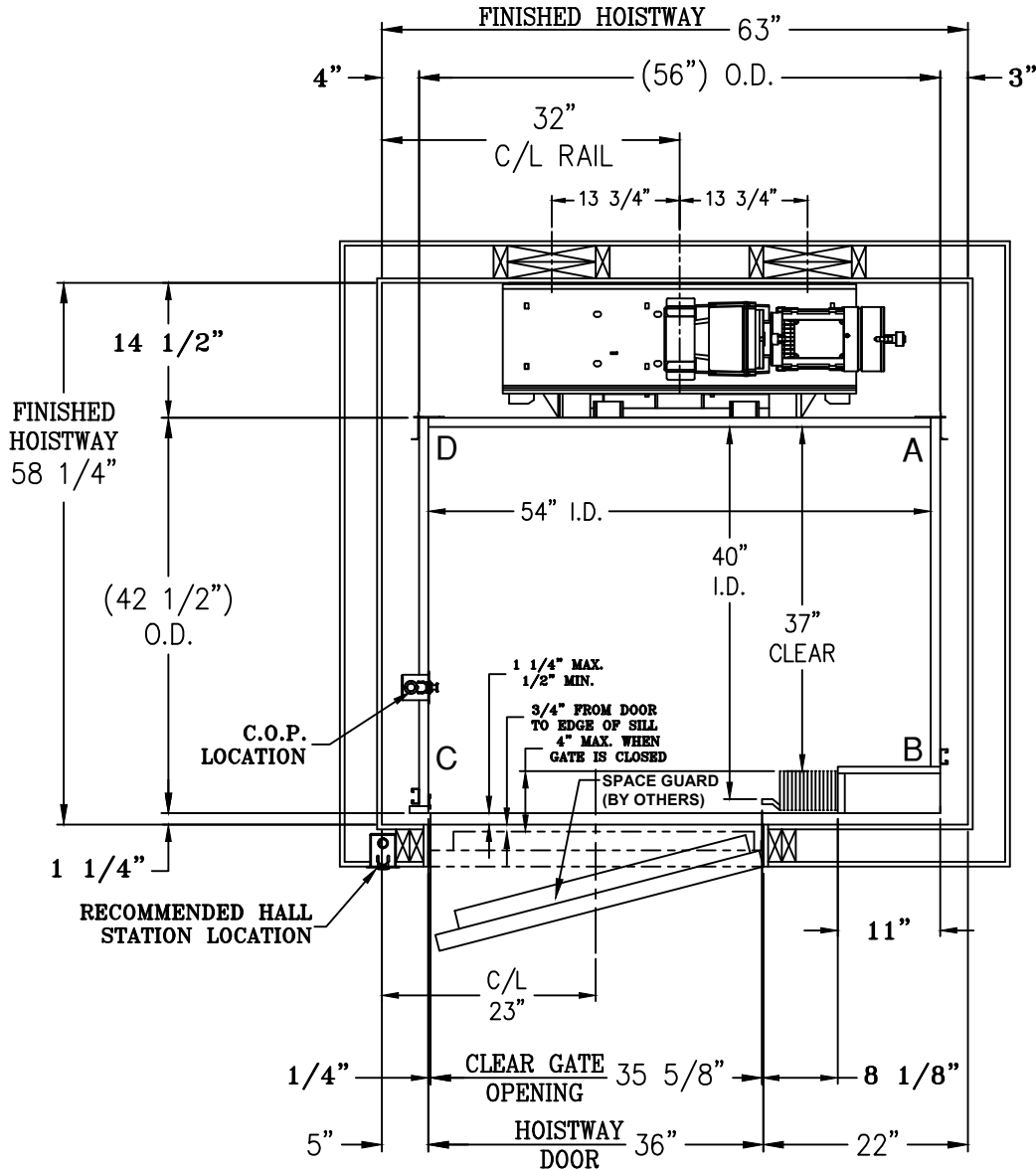

- 1) HOISTWAY BY OTHERS PER CODE. WALLS TO BE PLUMB AND SQUARE. ALL HOISTWAY DOORS BY OTHERS PER CODE.
- 2) FINISHED HOISTWAY = ROUGH FRAMING + DRYWALL + PLASTER + PAINT.

FOX VALLEY		1726 North Ballard Road Appleton, WI 54911 Phone: 800-238-8739	
ELEVATOR ™			
ELEVATOR CONTRACTOR:			
JOB NAME:		ORDER NUMBER:	
EXCELEVATOR SERIES			
CHAIN DRIVE ELEVATOR			
BC OPENING W/ ACCORDION GATE			
DRAWN BY:	DATE:	SIGNATURE OF APPROVAL	DWG. NO.
			C-003253