

DOOR SPACE GUARD REQUIRED TO COMPLY WITH ASME A17.1-2019 SECTIONS 5.3.1.8.2 AND 5.3.1.9.3 (b). CONTACT LOCAL CODE AUTHORITY FOR SPACE GUARD SIZE REQUIREMENTS.

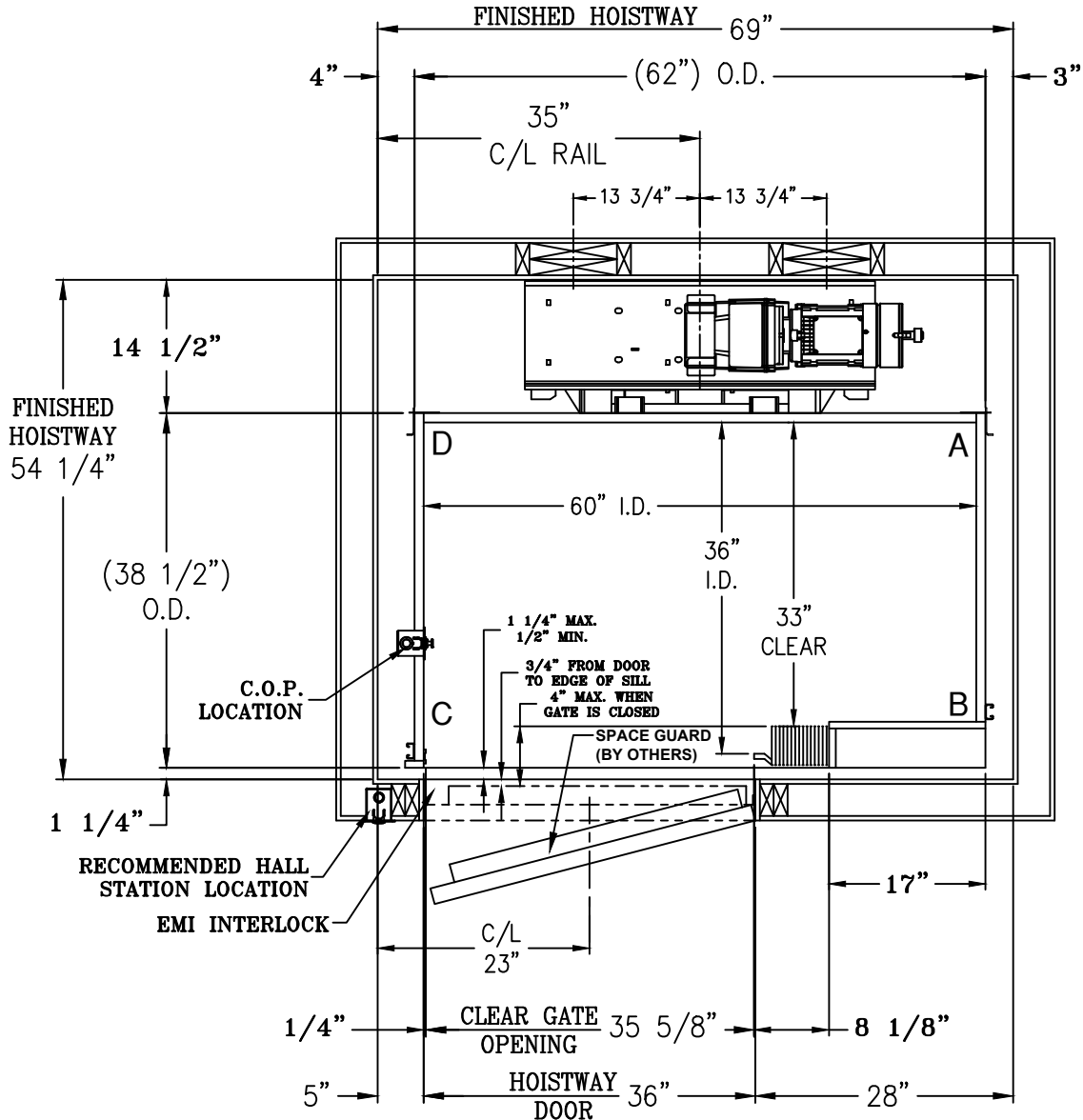

- 1) HOISTWAY BY OTHERS PER CODE. WALLS TO BE PLUMB AND SQUARE. ALL HOISTWAY DOORS BY OTHERS PER CODE.
- 2) FINISHED HOISTWAY = ROUGH FRAMING + DRYWALL + PLASTER + PAINT.

| | | | |
|-------------------------------------|-------|--|-----------------------------|
| FOX VALLEY | | 1726 North Ballard Road Appleton, WI 54911 Phone: 800-238-8739 | |
| ELEVATOR ™ | | | |
| ELEVATOR CONTRACTOR: | | | |
| JOB NAME: | | ORDER NUMBER: | |
| EXCELEVATOR SERIES | | | |
| CHAIN DRIVE | | | |
| BC OPENING W/ ACCORDION GATE | | | |
| DRAWN BY: | DATE: | SIGNATURE OF APPROVAL | DWG. NO. C-003239 |