

DOOR SPACE GUARD REQUIRED TO COMPLY WITH ASME A17.1-2019 SECTIONS 5.3.1.8.2 AND 5.3.1.9.3 (b). CONTACT LOCAL CODE AUTHORITY FOR SPACE GUARD SIZE REQUIREMENTS.

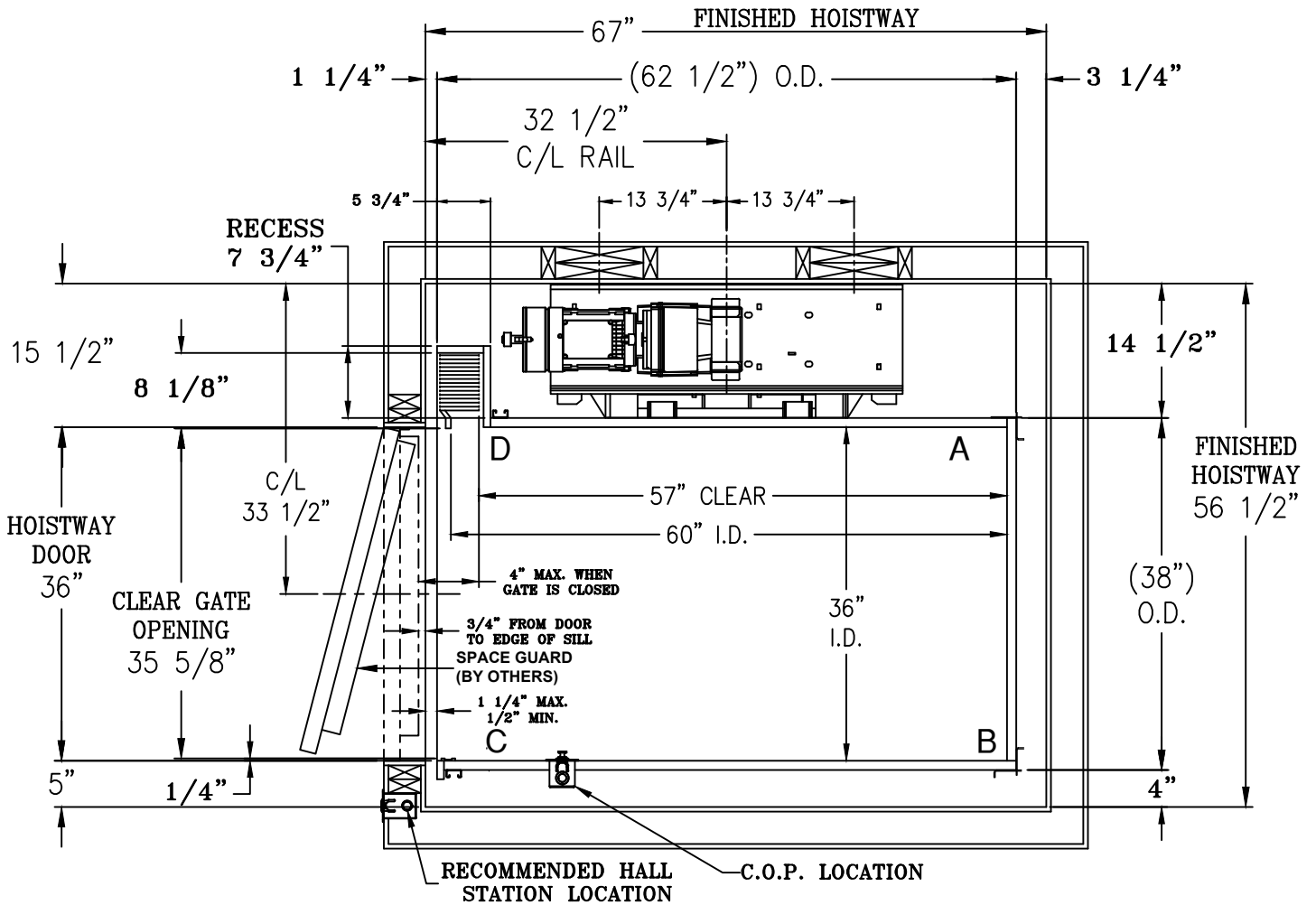

- 1) HOISTWAY BY OTHERS PER CODE. WALLS TO BE PLUMB AND SQUARE. ALL HOISTWAY DOORS BY OTHERS PER CODE.
- 2) FINISHED HOISTWAY = ROUGH FRAMING + DRYWALL + PLASTER + PAINT.

FOX VALLEY
ELEVATORTM

1726 North Ballard Road
 Appleton, WI 54911
 Phone: 800-238-8739

ELEVATOR CONTRACTOR:

JOB NAME:

ORDER NUMBER:

EXCELEVATOR SERIES
CHAIN DRIVE ELEVATOR
DCR OPENING W/ ACCORDION GATE

DRAWN BY:

DATE:

SIGNATURE OF APPROVAL

DWG. NO.

C-003259