

BI-PART GATE

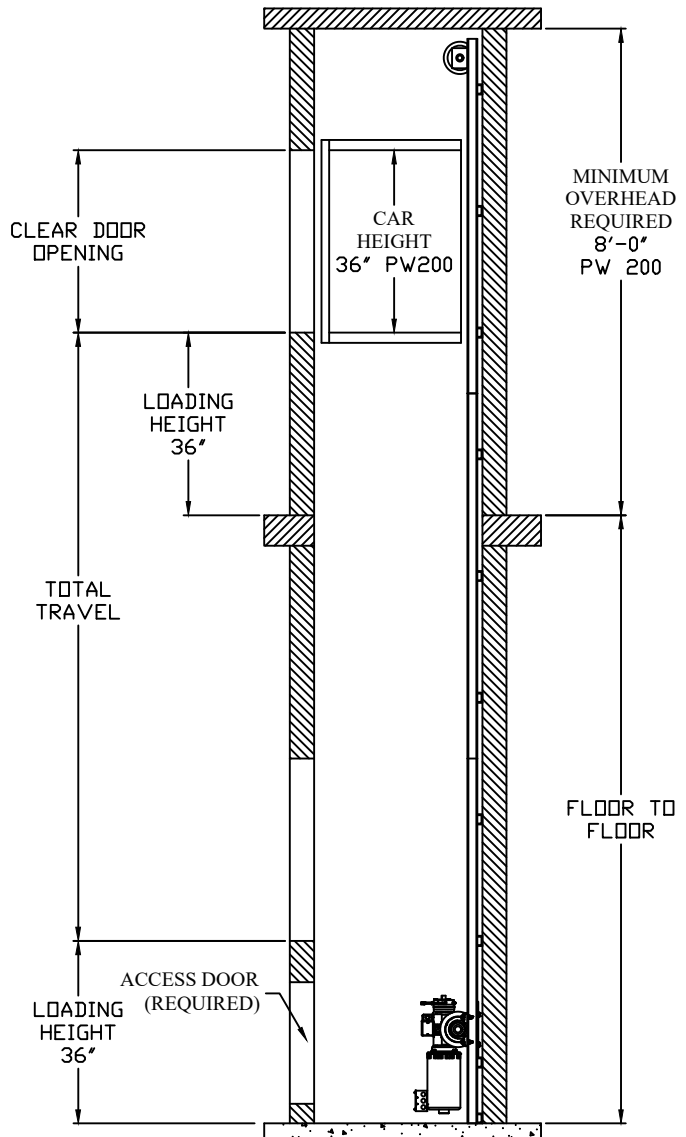

ROLLTOP GATE

FOX VALLEY ELEVATOR TM
 1726 North Ballard Road
 Appleton, WI 54911
 Phone: 800-238-8739

ELEVATOR CONTRACTOR:			
JOB NAME: ELEVATION LAYOUT		ORDER NUMBER:	
PACA-WAITER (011) ELEVATION LAYOUT 2 STOP W/GATE MOTOR BELOW			
DRAWN BY:	DATE:	SIGNATURE OF APPROVAL	DWG. NO. C-003034